

STREETSCAPE: PLAN

SCALE: 1/2"=1'-0"

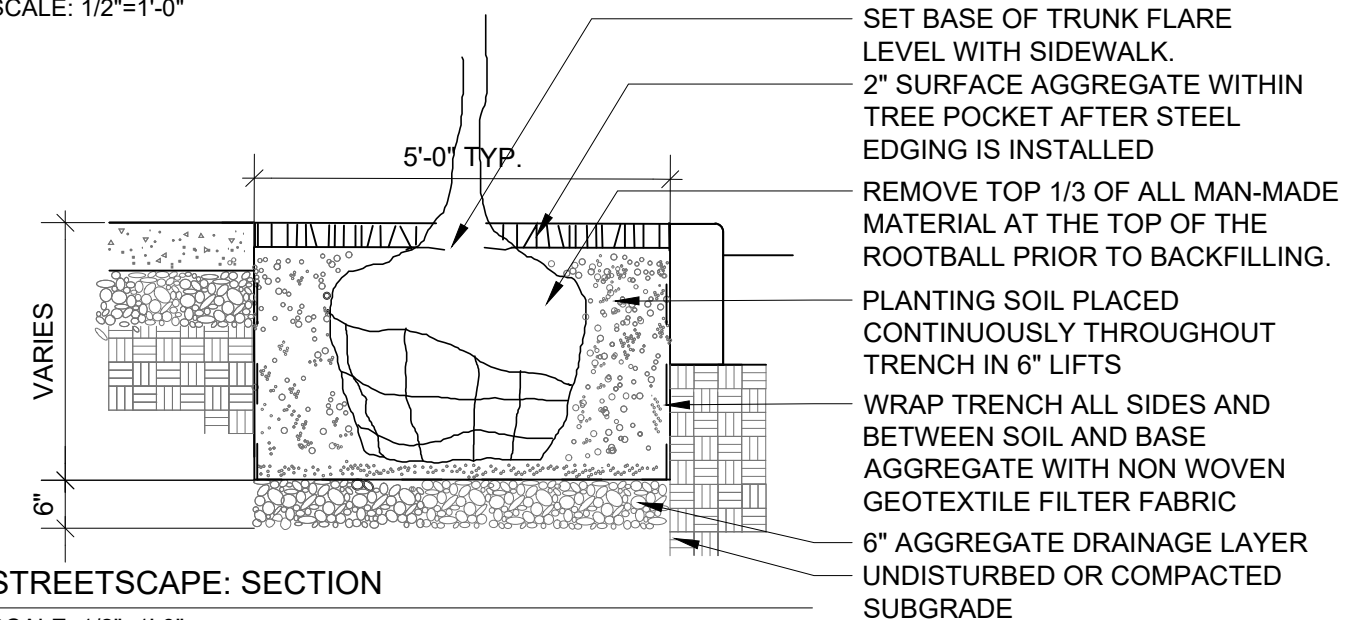

STREETSCAPE: SECTION

SCALE: 1/2"=1'-0"

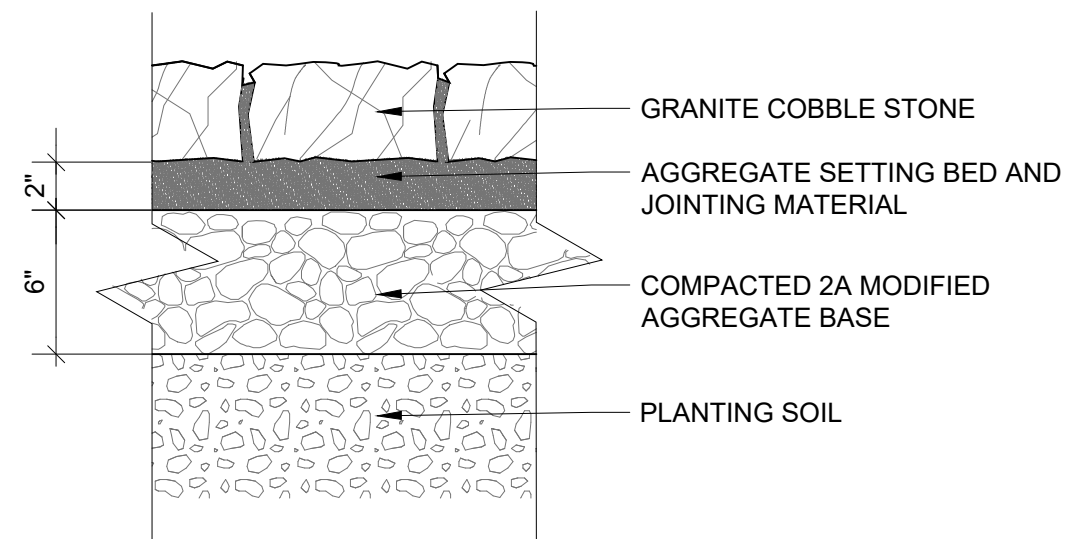

GRANITE COBBLES: SECTION

SCALE: 1-1/2"=1'-0"

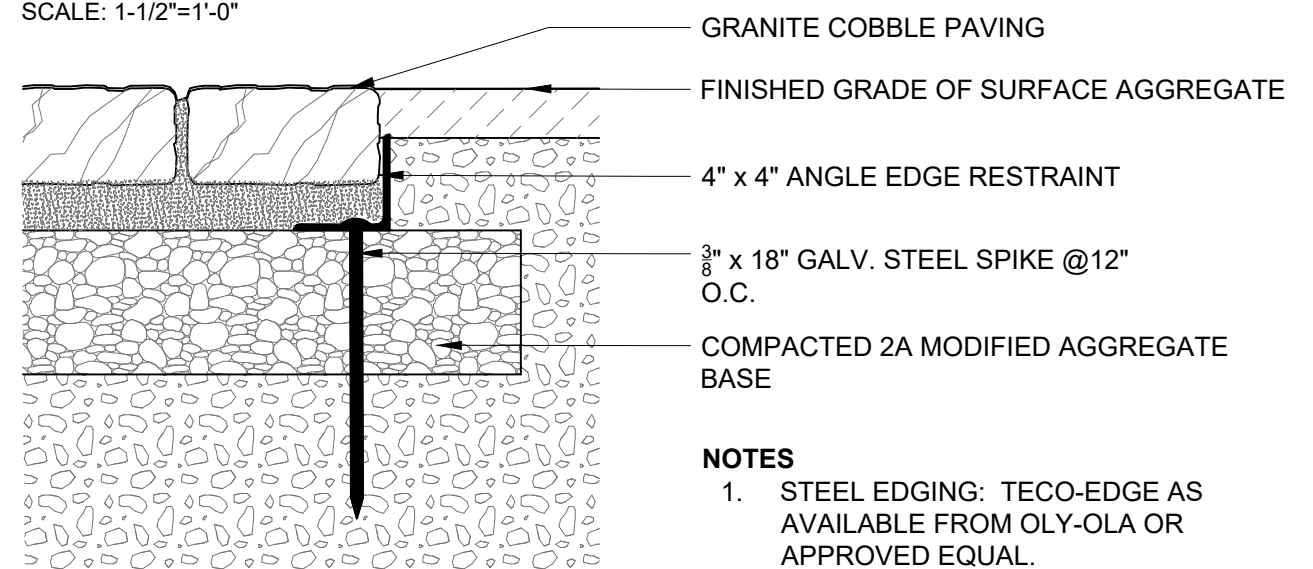

STEEL EDGING: SECTION

SCALE: 1-1/2"=1'-0"

PLANTING SOIL REQUIREMENTS

NATIVE PLANTING SOILS: UTILIZE TOPSOIL STRIPPED ONSITE AND TESTED. IF NECESSARY, SOILS SHALL BE AMENDED AT THE TIME OF INSTALLATION TO ACHIEVE THE FOLLOWING PARAMETERS:

- pH RANGE OF 5.5 TO 7.0
- PERCENT ORGANIC MATTER 3% - 8%
- MICRO NUTRIENTS SHALL BE TESTED FOR REQUIRED AMENDMENTS

MANUFACTURED PLANTING SOILS: FOR USE IN AREAS WHERE NATIVE SOILS ARE NOT AVAILABLE DUE TO LIMITED AVAILABILITY OF TOPSOIL. MANUFACTURED SOILS AND NATIVE TOPSOILS SHOULD NOT BE BLENDED TOGETHER.

NOTES

1. STEEL EDGING: TECO-EDGE AS AVAILABLE FROM OLY-OLA OR APPROVED EQUAL.

CSI 32 16 41
STREETSCAPE
LANDSCAPE STANDARDS



PRIOR TO CONSTRUCTION, CONFIRM LAYOUT, DIMENSIONS, ADJACENT UTILITIES AND FINAL MATERIALS WITH U OF P OFFICE OF THE UNIVERSITY ARCHITECT. THIS DETAIL TO BE USED AS A GUIDE ONLY. SPECIFIC REVISIONS FOR SITE CONDITIONS AND INTENT ARE THE RESPONSIBILITY OF THE INDIVIDUAL PROJECT DESIGNER.

Facilities & Real Estate Services
Office of the University Architect
2022